

Panasonic

BUILT TOUGH WITH HIGH QUALITY WEATHER PROOF OUTDOOR SWITCH & ENCLOSURE



HIGHLY DURABLE



GRADE RATING



SAFETY FEATURES



FEATURES

- Products are made from tough thermoplastic materials and are suitable for indoor and outdoor use where corrosion resistance and moisture resistance are required.
- The products offer an ingress protection code of IP66 at all times, provided the product is installed correctly, the lid is closed and the cable correctly positioned through the center of the gel seal.
- The switch product has a fluorescent indicator light that stays lit when the switch is off.
- The cover product comply with the IEC 60670-1 and the Switch product comply with the IEC 60669-1 standards. Both products comply with IEC 60529-IP66 standards.
- European RoHS directive compliant, Completely free from Cd, Hg, Cr6+ , Pb, PBBs, PBDEs.

SWITCHES

RANGE



Push Switch 1-Gang 1-Device
WBKC5511



2Way Switch 1-Gang 1-Device
WBKC5212



2Way Switch 1-Gang 2-Devices
WBKC5222

TECHNICAL SPECIFICATIONS

- Rating
 - WBKC5511 : 10A 250V~
 - WBKC5212 : 20A 250V~
 - WBKC5222 : 20A 250V~
- Standards
 - Comply with IEC 60669-1
 - IEC 60529-IP66
- Terminal screw-type (rigid and flexible)
- Applicable Wire
 - WBKC5511 : 1.0 mm² - 2.5 mm²
 - WBKC5212 : 2.5 mm² - 6 mm²
 - WBKC5222 : 2.5 mm² - 6 mm²
- Ambient Temperature -5°C - +40°C
- Terminal Capacity
 - WBKC5511 1.0mm² x 2, 1.5mm² x 2, 2.5mm² x 2
 - WBKC5212 2.5mm² x 2, 4.0mm² x 2, 6.0mm² x 2
 - WBKC5222 2.5mm² x 2, 4.0mm² x 2, 6.0mm² x 2
- Representative Performance
 - Electric strength : 2000V 1min
 - Operation test :
 - WBKC5511 : 40000 Operations
 - WBKC5212 : 10000 Operations
 - WBKC5222 : 10000 Operations
- Temperature rise :
 - Not more than 45K(Terminals)
 - ※K=absolute temperature

DIMENSIONS

Unit: mm

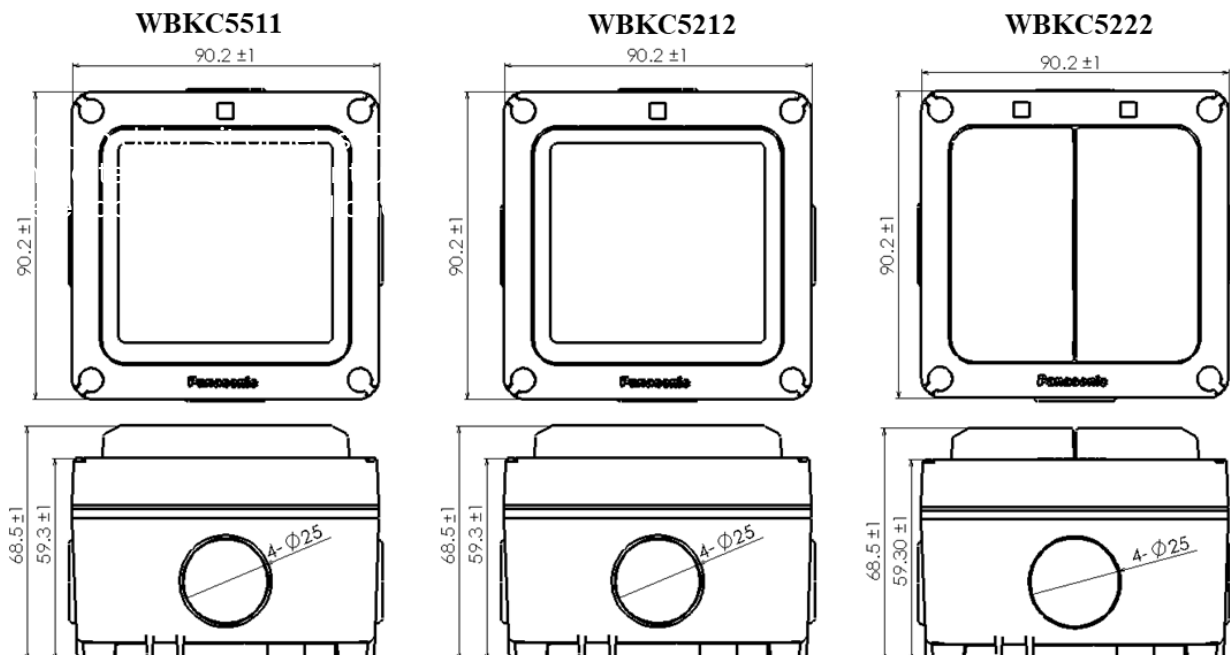

ENCLOSURES SINGLE AND DOUBLE

RANGE:

1-Gang Enclosure Only
WBKC8911



2-Gang Enclosure Only
WBKC8921



CONFIGURATION EXAMPLES

* The single and double enclosures can fit almost all the products of Harmony Series



1G 13A Socket
WBKC8911 +
WBC1212



2G 13A Socket
WBKC8921 +
WBC1222



Fused Connection
WBKC8911 +
WBC7103



2D 6G switch
WBKC8921 +
WBC5061



2D RJ11 (6P4C)
WBKC8911 +
WBC3128

TECHNICAL SPECIFICATIONS & DIMENSIONS FOR ENCLOSURES

Unit: mm

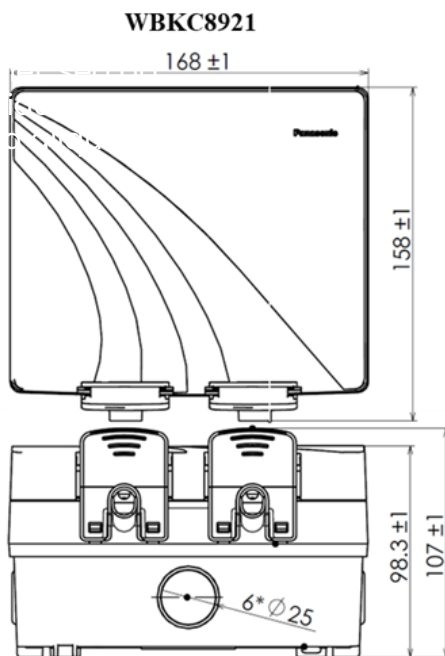
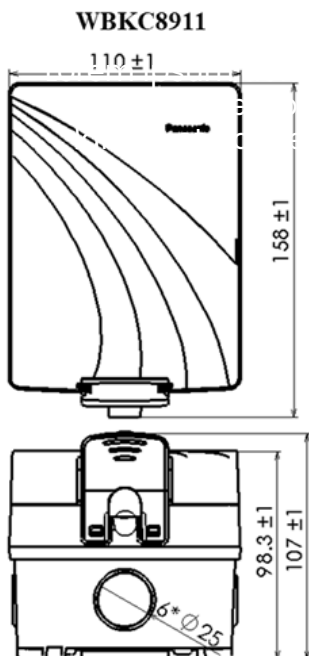

- Standards:
Comply with IEC 60669-1
IEC 60529-IP66
- Ambient Temperature:
-5°C - +40°C

REFERENCE:

MODEL NO	DESCRIPTION	RATING
WBKC5511	Push Switch 1-Gang 1-Device	10A 250V~
WBKC5212	2Way Switch 1-Gang 1-Device	20A 250V~
WBKC5222	2Way Switch 1-Gang 2-Devices	20A 250V~
WBKC8911	1-Gang Enclosure Only	
WBKC8921	2-Gang Enclosure Only	

WHAT IS IP RATING

First Digit	Intrusion Protection	Second Digit	Moisture Protection
0	No Protection.	0	No Protection.
1	Protected against solid objects over 50mm, e.g. accidental touch by hands.	1	Protected against vertically falling drops of water, e.g. condensation.
2	Protected against solid objects over 12mm, e.g. fingers.	2	Protected against direct sprays of water up to 15 degrees from the vertical.
3	Protected against solid objects over 2.5mm, e.g. tools & wires.	3	Protected against direct sprays of water up to 60 degrees from the vertical.
4	Protected against solid objects over 1mm, e.g. tools & nails.	4	Protected against water splashed from all directions, limited ingress permitted.
5	Protected against dust limited ingress, no harmful deposits.	5	Protected against low pressure jets of water from all directions, limited ingress permitted.
6	Totally protected against dust.	6	Protected against strong jets of water, e.g. On ships deck, limited ingress permitted.

Panasonic®

Panasonic Marketing Middle East & Africa FZE
P.O. Box 17985, Dubai, U.A.E. Tel: +971 8007262
customer@ae.panasonic.com | www.panasonic.com